



TECHNICAL UNIVERSITY OF CLUJ-NAPOCA

ACTA TECHNICA NAPOCENSIS

**Series: Applied Mathematics and Mechanics
Vol. 54, Issue II, 2011**

**SIMULATION OF CNC MACHINING PROCESS USING CAM SOFTWARE
- RELIABLE SOLUTION FOR TRAINING STUDENTS**

Florin POPIȘTER, Radu RĂCĂȘĂN and Timea GYÖRKE

***Abstract:** In recent years NC production equipment has been incorporated in the manufacturing process, on a larger scale. Today, operating and programming a CNC machine tool is performed in a simple and easy way with the help of a CAM (Computer Aided Manufacturing) software. Building on the basic knowledge about milling or turning and using specific CAM software, students can create a usable NC file (code) for CNC machine tools that can be used to perform the actual manufacturing processes. The use of CAM software for programming a CNC machine tool is very important these days as the number of controller types and specifications has increased, and because the development of CNC machine tools with more than 3 axis makes it more difficult to build suitable NC files. The training process in the field of NC programming can be optimized by employing interactive simulation software to highlight certain concepts and to help students assimilate information and gain competences faster. This paper presents a case study that highlights the advantages of using a CAM software for training students on how to generate a NC machining file for a 3 axis CNC machine tool.*

***Key words:** CNC machining process, CAM software, reliable solution, training students*

1. INTRODUCTION

The concept of Computed Numerically Controlled CNC equipment refers to machinery operated using programmed commands and is widespread in many areas of the industry. There are several types of programmable production equipment using numerical command: lathes, multi axes manufacturing equipment. The operator of this equipment must be familiar with the techniques and methods of machining and turning as well as operating procedures and instructions that allow him to set up and run the code on the machines. In order to acquire the necessary skills required for programming a CNC equipment students make use of CAM software that combines powerful simulation capabilities in a process of learning by doing.

Simulating the trajectory of the cutting tool or simulating the process by using the ISO file containing code G program, necessary for the command of CNC machine tools can prove to be an important step before beginning the actual manufacturing process of the parts.

Simulation is a great tool for reducing setup time and waiting time between processing operations of the manufacturing equipment, ensuring at the same time that the chosen strategies for the manufacturing process were correctly implemented [1][2].

Manufacturing process simulation is a very important step before starting the actual processing on CNC machine tool because it is the last step where problems and mistakes can be identified and corrected. This step is crucial, especially for high volume manufacturing systems where setting and optimising the manufacturing parameters, to ensure safe operation of the equipment and reduced costs and manufacturing time.

This paper aims to help students understand the fundamentals of NC machining through simulation of the manufacturing process using a wide range of virtual CNC machine tools, found in the CATIA V5 software. Computer simulation is used in order to easily understand and learn methods for checking the NC code compiled beforehand. Students can thus understand how to use, verify and optimize

generated NC programs or determine what functions and commands are required for operating CNC machine tool.

2. SIMULATING THE MANUFACTURING PROCESS USING THE MODULE PRISMATIC-MACHINING FROM CATIA V5

Dassault Systèmes, the company developing the CATIA V5 software integrates within a dedicated CAM module that offers the possibility of simulating the manufacturing process on CNC controlled equipment and the ability to view the movements of the cutting tool during the simulation. These so called end-to-end solutions are included in the *PLM-Product Life Management* architecture, allowing NC programmers to switch between tool path definition and validation without losing time with the data transfer, thus reducing lead time and costs [3][4][5].

The user-friendly interface of *Prismatic Machining* module helps the user define and generate tool paths within a manufacturing operation by following a well-defined and structured algorithm. Dialog boxes, which have intuitive graphics, help users easily, find the desired buttons and icons. In this way the user can select very easy the desired area that wants to machine even to change some parameters of the tool as presented in Figure 1.

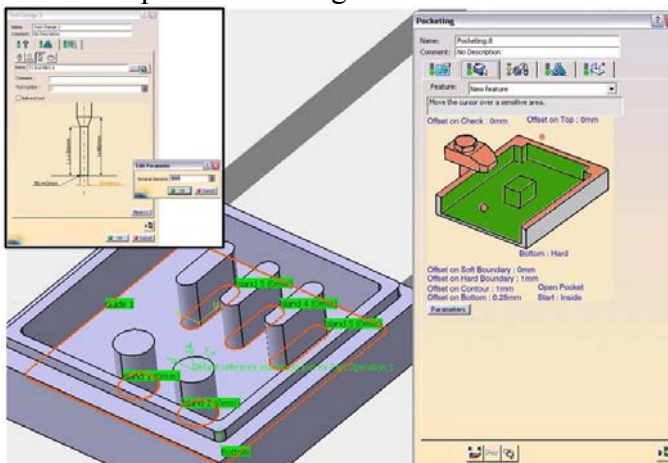

Figure 1. Intuitive dialog boxes

Tool changes and the rotation moves of the CNC machine tool are automatically generated and can be viewed in the definition panel processing operations.

The geometry of the workpiece it is made under a “history tree”. In this way every change

that the users will make on the workpiece, after realizing a machining process on a certain area, CATIA V5 software it will automatically update that certain manufacturing process.

CATIA V5 software has the possibility to recognize both the design and manufacturing feature creating an boundary on the part model, considering the geometrical and technological parameters. It is not necessary to make the transition from CAD software to CAM software because CATIA V5 is a whole unit. The switching from the *Part Design* module to *Prismatic Machining* is done by choosing from the pull down menu *Start* in CATIA V5.[1][6]. Using the simulation from CATIA V5 CAD/CAM software students will be able to easily understand and learn how to:

- defining the zero point of the workpiece as shown in Figure 2;
- define a safety plane;
- establish the start point and the end point where to begin the machining process;
- choose and define the tools;
- tool change used in different machining sequences;
- generate correct tool paths;
- identification of the possible collision areas and change the tool path;
- understand the difference between cutting speeds, cutting depths or cutting feed;
- risk free to use the NC file obtained after the machining process is checked through a simulation;

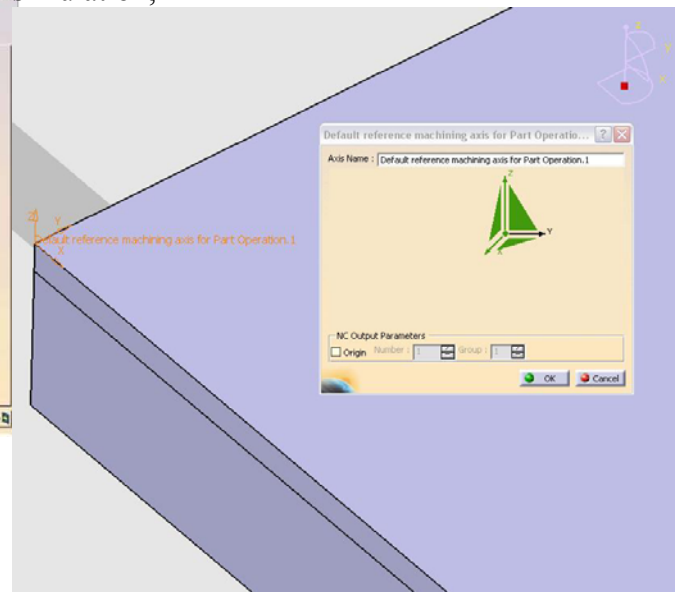

Figure 2. Defining reference plane

Using the *Replay Toolpath* simulation, the software can highlight possible resulted collisions but the user can also view the positioning of the tool during machining. The simulation of the tool path trajectory is made after choosing the desired manufacturing strategy in the area that will be processed and generating related path. This offers to the user the possibility of visualising the exact coordinates of the tool by positioning it with the mouse. The coordinates are displayed in the window frame of the simulation, in the command box.

The resulted processing times depend on the technological characteristics of the process: cutting speeds, cutting depths or cutting feed chosen for the tool. These parameters are displayed in the window alongside the simulation. The command box is suggestive and it shows what part of the program or strategy is viewed and simulated in that moment. The title of the simulation is displayed in the upper left corner, pocketing, as shown in the example in Figure 3.

Positioning the workpiece in the workspace and defining the limits of the manufacturing areas on CNC machine tool should be done when starting a machining process. Tool path simulation is very suggestive and helps students understand and learn how to position the tool in the workspace and to select the work strategy so as to obtaining the tool path.

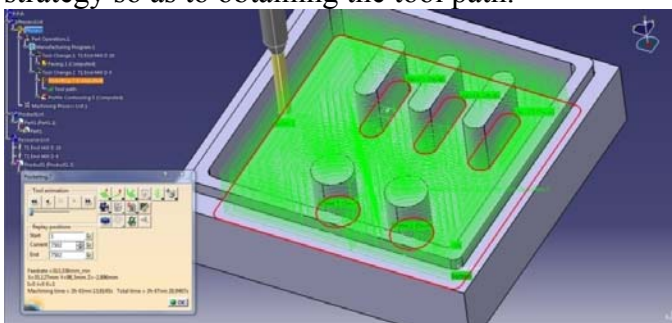

Figure 3. Simulating the machining process using the tool path

If there are any mistakes in the tool path generation, the program can be rerun using the *Cycle Instant Update* option. This feature is designed to help students save time on recalculation of tool trajectories, after the necessary changes have been made.

The user can visualise the machining cycle simulation directly on the modeled semi-finished workpiece. The simulation presented

in Figure 4 shows the way in which the material is removed and also highlights at the same time any mistakes that may appear during the manufacturing cycle such:

- collisions between the workpiece and the cutting tool
- areas that are not machined to the desired specifications
- areas where the machining process has left surplus material
- improper selection of cutting tools
- machining strategies that are not suitable.

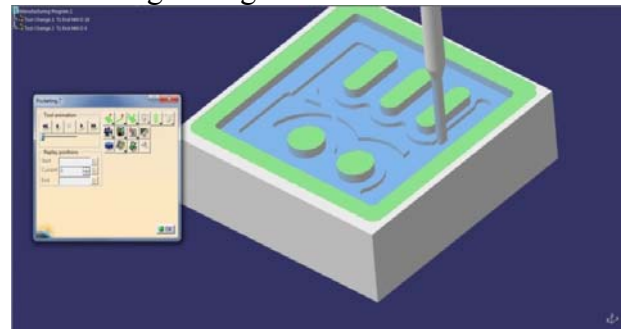

Figure 4. Simulating the machining operations on a semi-fabricated workpiece

Machining certain areas of the workpiece using different machining strategies can easily be highlighted because CATIA V5 enables the user to change the colour of each machining strategy. The semi-finished workpiece can be split up based on various machining depths each with its separate offset zone so the user can select for each area the tools and the machining strategy to be implemented.

One of the main features of the Machining module in CATIA V5 is the automatic generation of the NC code. The data generated includes the tool's trajectory using as a source the APT files and at the same time generating the numerical command data in ISO format with the help of the integrated libraries of standardized postprocessors. The user is able to import personalized post processors tailor made to their own particular equipment.

After the trajectories of the machine tools have been simulated and all parameters have been set the last step of the process is to generate the NC code.

Simulating the machining process on a line by line basis as enables the user to better understand the action generated by the M functions in the programming stage and also the G codes. The simulation shows all the

movements of either the workpiece or the cutting tool during machining.

When using a graphical simulation based on the numerical control code generated beforehand it is important that the proper equipment for NC command is employed. CATIA V5 allows the user to insert custom made equipment's different from those already available in the software libraries into this type of simulation. The simulation can be stopped at any moment making it possible to select individual lines of the code in order to observe the command and its effect on the machining process.

Using simulation to learn NC manufacturing students can experience the whole process in a virtual environment without the need for specialized tools and equipment. Because a wide variety of machining tools can be selected from the library this mode of training provides a general or a custom learning experience that is not confined to any particular make or equipment type.

3. STUDENT KNOWLEDGE AFTER SIMULATION USING CATIA V5

Teaching students how to design, implement, verify and simulate a program for NC manufacturing using advanced CAM software is a reliable solution.

Tool path simulation is very suggestive for the students to understand easily how the trajectories are created and what is for example the notion of circular interpolation made by the tool. Circular interpolation is the translation of linear axis positions into curved tool motion.

Students can easily understand from the tool path simulation the meaning of where the endpoint is or what is the feed rate and direction of the movement as shown in Figure 5.

The resulted G code is used in the simulation of the machining process and the students can visualize the moves of the CNC machine tool alongside the NC program which is running line-by-line. This way of displaying the data is

very relevant for the student to understand exactly each G code or M functions from an NC program.

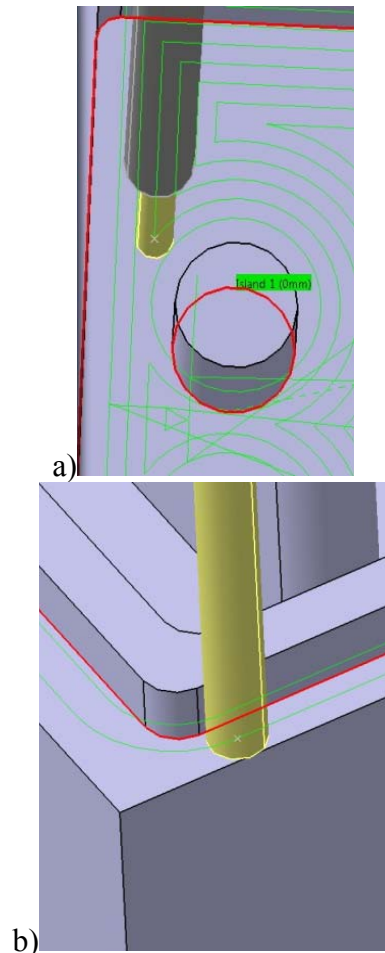

Figure 5. Examples of circular interpolation using strategies a) pocketing and b) profiling

Once the code has been generated the whole process can be simulated in a mode that runs the code line by line.

The user visualises the process more easily when running the code in this way, because he can see exactly each parameter in the code and its action on the machining process. This tool is very useful in the training stages where running the code line by line and visualising the process using simulation increases the overall learning experience of the trainee and at the same time help the student gain the necessary competences in learning by doing scenario as shown in Figure 6.

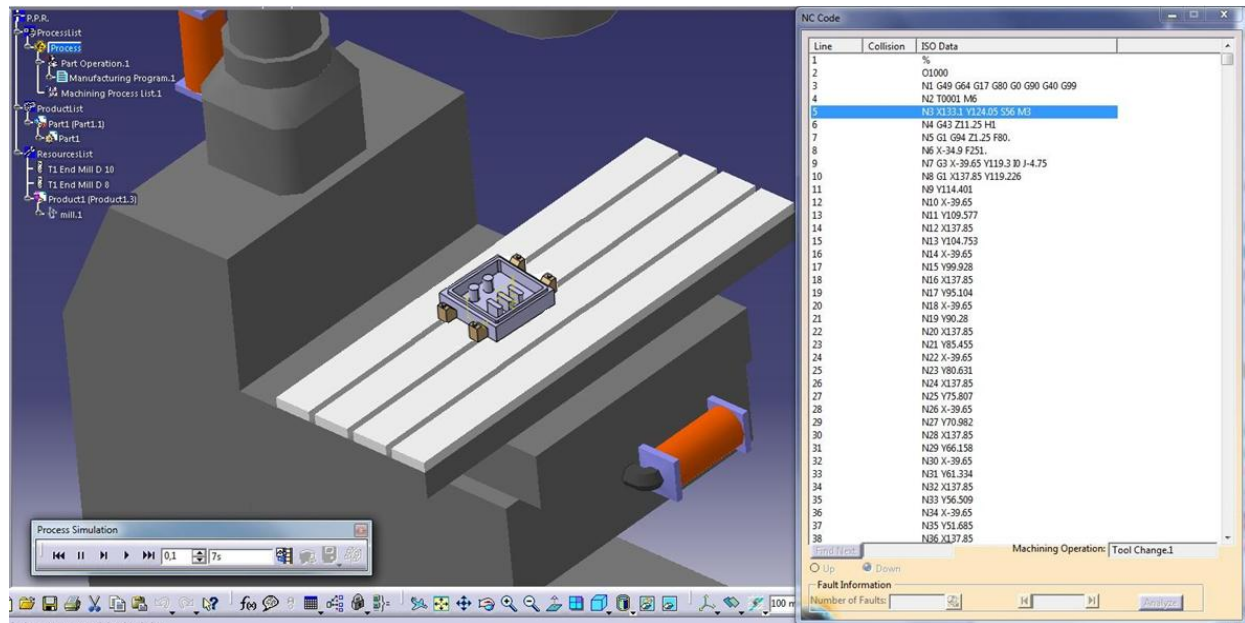

Figure 6. Simulating the machining process using the G code

The simulation can be stopped at any time and a specific line of code can be selected in the NC code window. The machine tool moves will be performed by the specific operations which are in the line of code, NC program, selected. Simulating using this feature of the software is very efficient in the learning phases of NC manufacturing because it allows the student to visualize every movement of the machine and every change of the cutting tool during the machining process.

Running the program directly on the screen with the machine tools which has the moves correlated with the lines from the program can help the student to understand more easily the meaning of tool change. In this case the student has the possibility to view exact line of program use for this command and the M function but also in the simulation he will see the moment when the automatic tool changer is performing the operation.

Different cycles of manufacturing, like tapping or drilling, can be easily explained to the student by displaying, how the drill performs the right moves when drilling the hole into the workpiece operations starts and what exactly the characteristics of this process are.

After going through all the steps, was generated using CATIA V5 software the NC file. It was used on a 3-axis CNC Vertical Machining Center and together with the students it was manufactured from plastic the

workpiece, as shown in Figure 7 that is given as example in this paper.

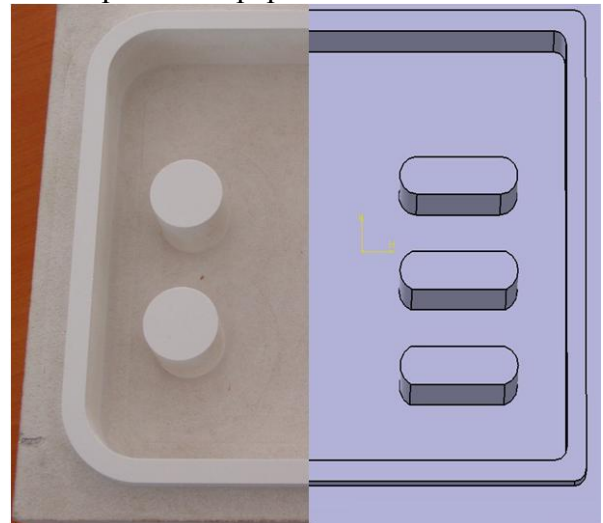

Figure 7. Machined workpiece

4. CONCLUSIONS

CATIA V5 is Computer Aided Manufacturing software that incorporates databases for various post processors and equipment used in CNC manufacturing. It allows the user to design all the manufacturing stages and also generates the code needed for NC machining. The software is a powerful solution for teaching CNC manufacturing because it incorporates a lot of features that are useful in the teaching/learning process. Students can learn how to select the proper equipment and then can visualize their programmed commands.

The virtual environment and interface of the software is familiar and easy to use while at the same time offering all the features necessary for learning CNC manufacturing. The software uses various resources in order to develop the student's practical abilities and programming skills necessary for programming a CNC machine. Simulation enhances the overall learning experience and allows the user to visualize the movements and operations of the equipment.

The interaction between the student and the software is achieved with the help of a graphical 3D interface, through animations of the programmed operations, and by allowing the user to visualize the cause and effect of each line of generated code.

By using e-learning solutions instead of traditional ones the learning process becomes more efficient, and the time and cost necessary for training are reduced. These training methods can be implemented for improving the skills of existing workers that are more familiar with the traditional manually controlled machining equipment.

Employing advanced design and simulation capabilities in the learning process greatly improves the interactivity and overall experience of the trainee while at the same time increasing the competences and knowledge gained.

5. ACKNOWLEDGEMENTS

This paper was supported by the project "Doctoral studies in engineering sciences for

developing the knowledge based society-SIDOC" contract no. POSDRU/88/1.5/S/60078, project co-funded from European Social Fund through Sectorial Operational Program Human Resources 2007-2013.

6. REFERENCES

1. CATIA V5 CAM from IBM/Dassault Systèmes A Product Review (http://www.cdcza.co.za/CATIA_machining_CIMDATA_report.pdf)
2. CATIA V5 Prismatic Machining 1 (PG1) (http://www.3ds.com/products/CATIA_V5/portfolio/CATIA_V5-v5/all-products/domain/Machining/product/PG1/?cHash=037538e6a398148454602281ea07bb61)
3. CATIA V5 Machining Solutions (ftp://ftp.software.ibm.com/software/plm/uk/CATIA_V5_v5_machining_solutions.pdf)
4. Machined Part Modeling for CATIA V5 (http://cadm.zut.edu.pl/pub/CATIA_V5/airbus%20-%20machined%20part%20modelling%20for%20CATIA_V5%20v5.pdf)
5. CATIA V5R19 - FACT SHEET (<http://www.plmsales.se/REF/CATIA-V5R19-factsheet.pdf>)
6. Wichita State University - CATIA V5 prismatic machining course (http://www.cadcamlab.org/course/images/Example_Manuals/Prismatic%20Machining.pdf)

SIMULAREA PROCESULUI DE PRELUCRARE UTILIZÂND UN SOFTWARE CAM - SOLUȚIE VIABILĂ PENTRU INSTRUIREA STUDENȚILOR

ABSTRACT: În ultimii ani echipamentele de producție cu comandă numerică sunt utilizate frecvent în procesele de prelucrare la scară largă. În zilele noastre operarea și programarea unei mașini CNC cu comandă numerică este realizată într-un mod simplu și eficient prin utilizarea unui software CAM (Computer Aided Manufacturing). Pe baza cunoștințelor fundamentale privind frezare și strunjire prin folosirea unui software CAM, studenții pot genera un fișier utilizabil care conține codul NC pentru mașinile cu comandă numerică și cu ajutorul căruia poate fi realizat procesul real de prelucrare. Folosirea unui software CAM pentru programarea mașinilor cu comandă CNC este benefică datorită numărului crescut de controllere și a specificațiilor acestora în special pentru mașinile cu mai mult de 3 axe. Procesul de instruire în domeniul programării NC poate fi optimizat prin aplicarea tehnicilor interactive de simulare cu ajutorul aplicațiilor software pentru a ilustra concepte, a permite studenților asimilarea rapidă a informației și dobândirea de competențe specifice. Lucrarea de față prezintă un studiu de caz care evidențiază avantajele utilizării unui software CAM pentru instruirea studenților în programarea și generarea fișierului NC pentru prelucrarea pe un centru de comandă numerică în 3 axe.