



NUMERICAL ANALYSIS OF STATE OF STRESSES AND DEFORMATIONS OF AN INDUSTRIAL SERIAL ROBOT 5R

Mihaela SIMION, Adrian-Ioan BOTEAN, Mircea BEJAN

Abstract. In this paper is presented a numeric analysis to determine the displacements and stresses for the strength structure of an industrial serial robot. This numerical analysis with finite element method consist in study of the robot when is loaded with maximum handling force, to realize a simple task like pick&place.

Keywords: analysis, finite element, displacements, stresses, robot.

1. INTRODUCTION

The numerical study has the purpose to determine the displacements and stresses for the strength structure of the industrial serial robot Fanuc LR MATE 100iB.

To determine the displacements and stresses on entire structure of the robot, has realized a numerical study in static mode, with Finite Element method (FEM) using Ansys 12.1 software (working module – Static Structural).

To perform this numerical study has chosen a working position of the robot, where arm 1 and rotation module, respectively arm 2 and arm 1 form a 90° angle.

In figure 1 is shown the CAD model of the studied robot with considered working position and the constructive elements of this.

The strength structure of the robot has established starting from structural study of this from technical documentation, more exactly the study of internal construction of the robot, the motion transmission mechanisms from driving motors to modules, of assembly of different mechanical, electrical and pneumatic parts, etc.

Thus, was observed that the internal parts are attached with housing by screws, and the rotation motion of the modules is transmitted from driving motors to modules through gears and reducers.

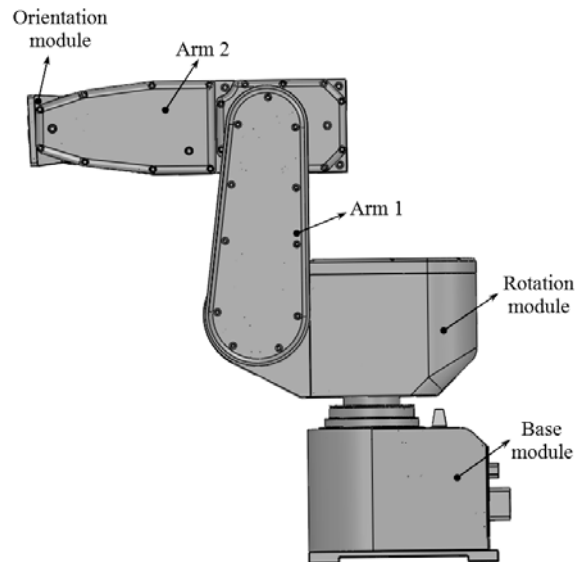

Fig. 1. CAD model of the robot

The efforts that arise inside of the robot from driving motors are taken, almost entirely, by housing (through screws), so we can say that the housing is the strength structure of the robot.

The material of the strength structure is iron alloy, having the following mechanical features:

- Density : $\rho = 7200 \text{ kg/m}^3$;
- Young's modulus :

$$E = 1,1 \cdot 10^5 \text{ N/mm}^2 ;$$

- Poisson ratio: $\nu = 0,28$;

- tensile ultimate strength:

$$\sigma_{r_i} = 280 \text{ N/mm}^2 .$$

2. NUMERICAL STUDY OF STRENGTH STRUCTURE OF THE INDUSTRIAL ROBOT

The numerical study was realized using the values of efforts obtained analytically in the paper [4], the robot being loaded with forces and/or moments corresponding to nodes 2, 3, 6, 7 and 8, which represents the gravity center of driving motors plus the maximum handling force $F_3 = 50\text{ N}$;

To perform the numerical study it was taken into account the following simplifying hypothesis and constrains:

- were not taken in study the rotation joints, gears and bearings and screws;
- the covers and their corresponding modules of the robot was considered a single body;
- the robot was fixed in the feet from the robot's base;
- the mesh of the structure was done automatically, choosing the dimension of finite element 30 mm, resulting 170.241 elements and 288.561 nodes.

In figure 2 is presented the mesh of strength structure of the robot realized with Ansys 12.1.

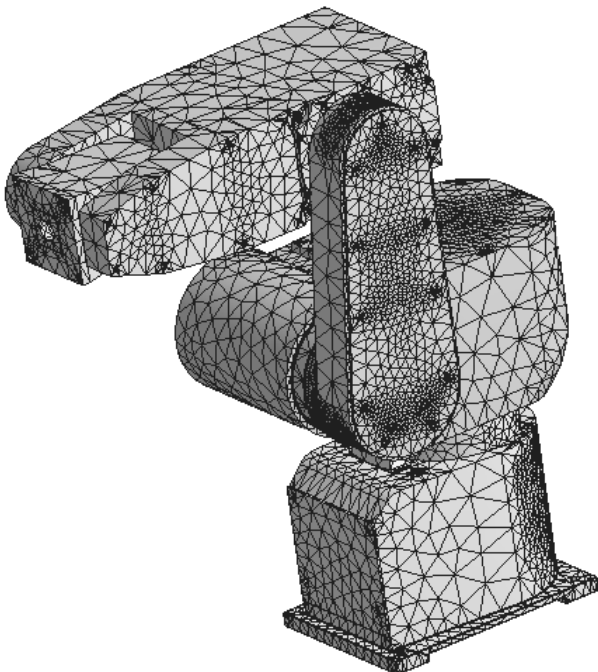

Fig. 2. The mesh of the strength structure of the robot Fanuc using Ansys 12.1

To perform the numerical study with FEM its starts from the base of the robot, adding one

module at a time, finally obtaining the global distribution of displacements and stresses.

Was approached such a procedure to observe the behavior of the strength structure under the loading action, and also to observe the evolution/variation of the distribution of displacements and stresses, from the base module to orientation module.

In figures 3 and 4 are presented the obtained distribution of displacements and stresses using FEM in static mode, for the chosen particular working position, and for a better view of the areas where the equivalent stresses (von Mises) are maxim has done details.

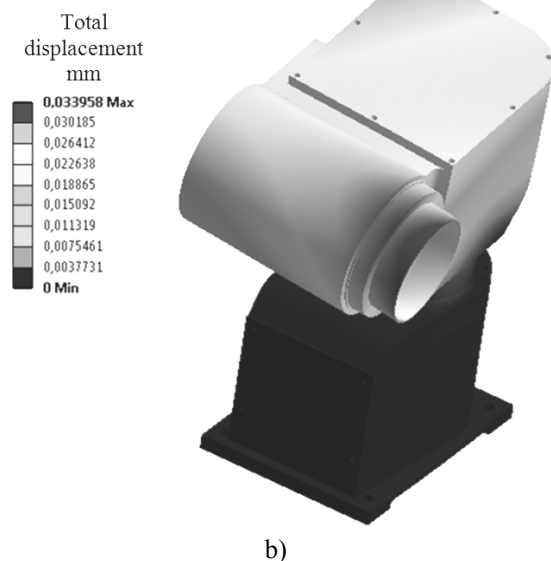
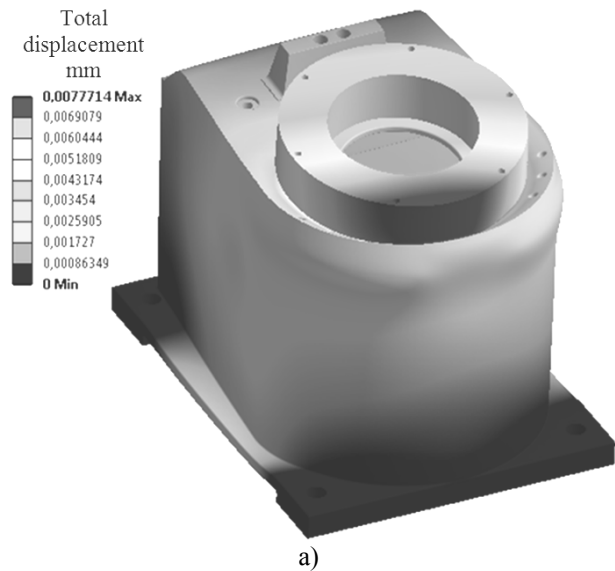

Fig. 3. Distribution of displacements obtained with FEM

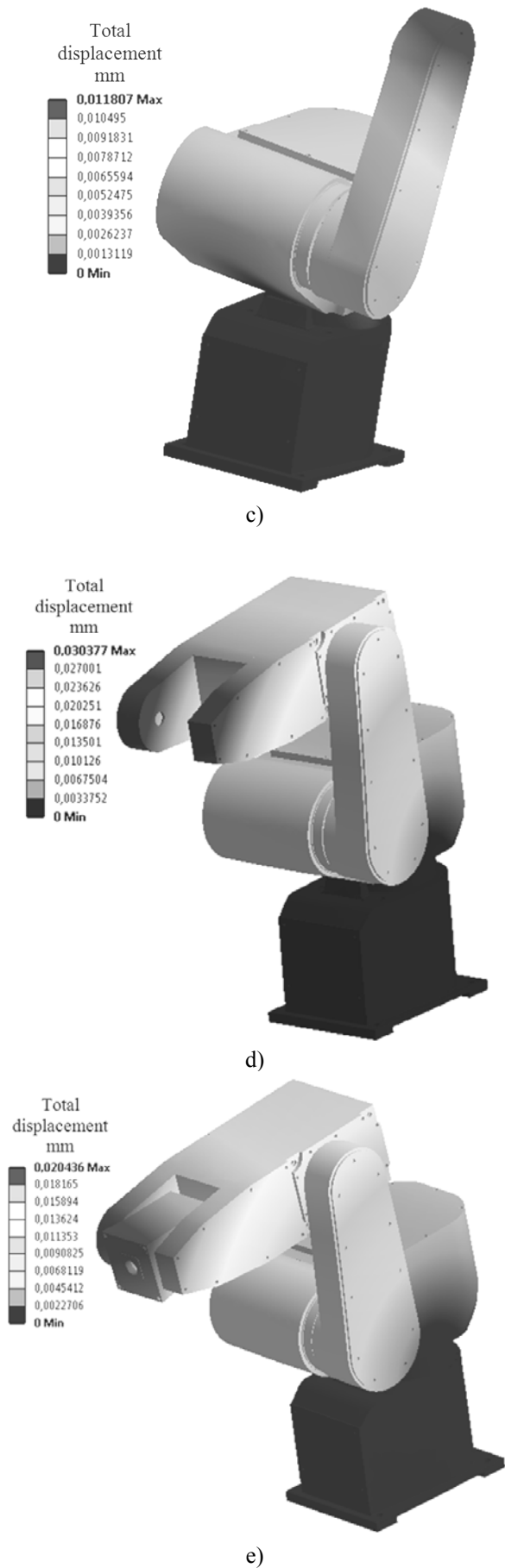

Fig. 3. Distribution of displacements obtained with FEM (continuation)

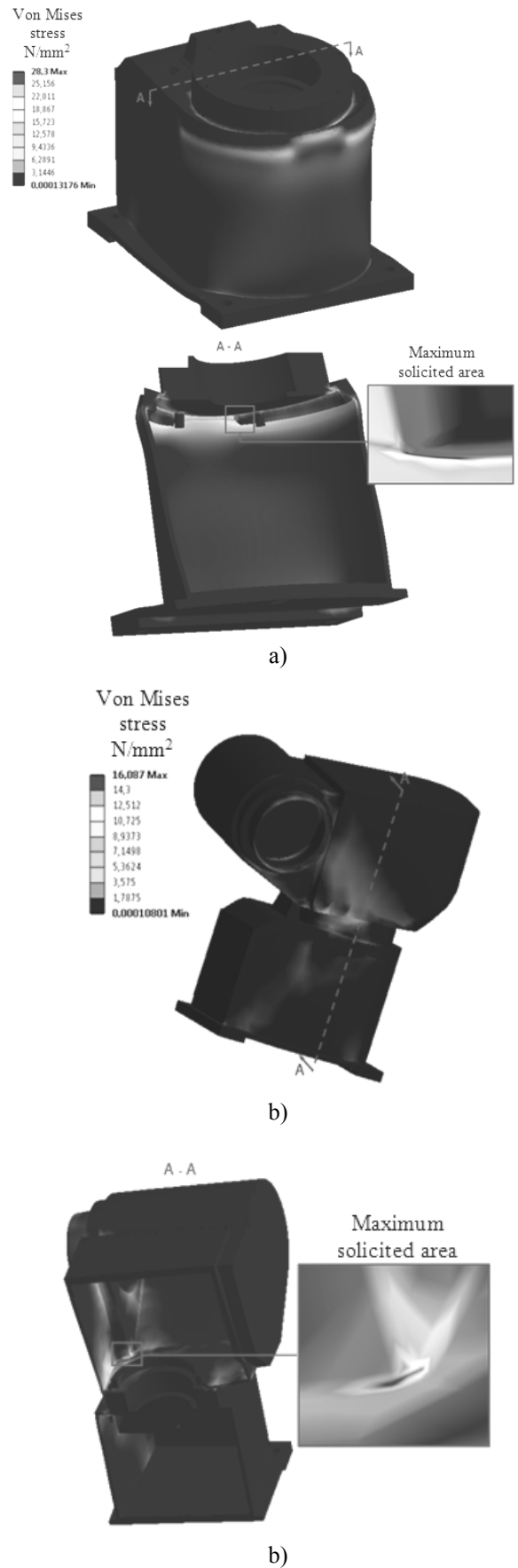

Fig. 4. Distribution of von Mises stresses obtained with FEM

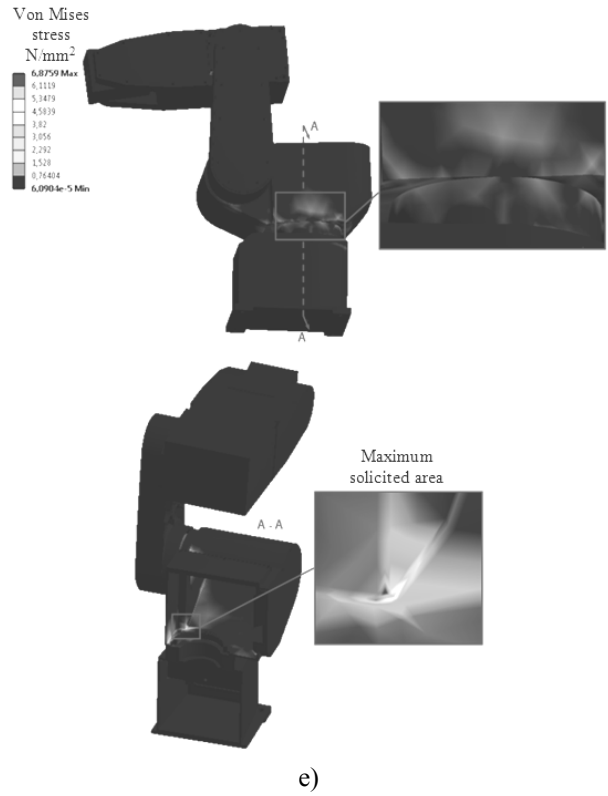
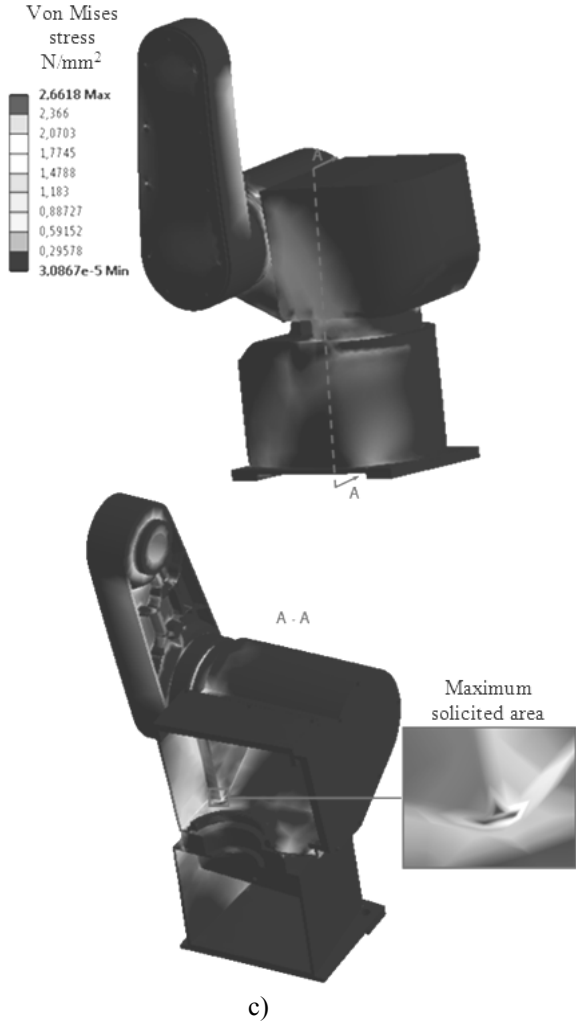

Fig. 4. Distribution of von Mises stresses obtained with FEM (continuation)

In table 1 has given the numerical values of maximum total displacements (by axis x , y and z) and of maximum von Mises stresses, and in figure 5 a) and b) are given the variation graphics of displacements and stresses according to application nodes of efforts.

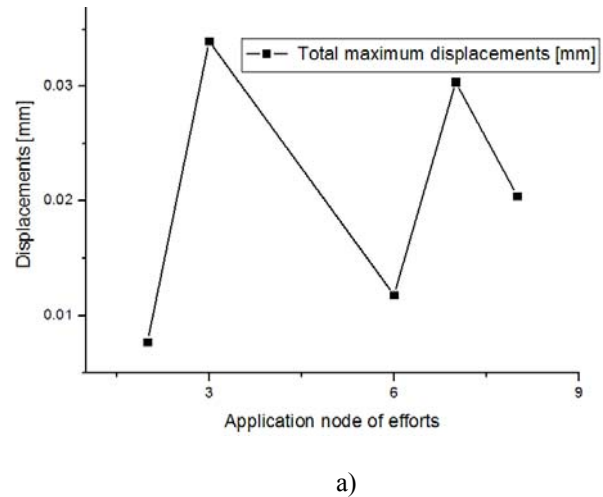
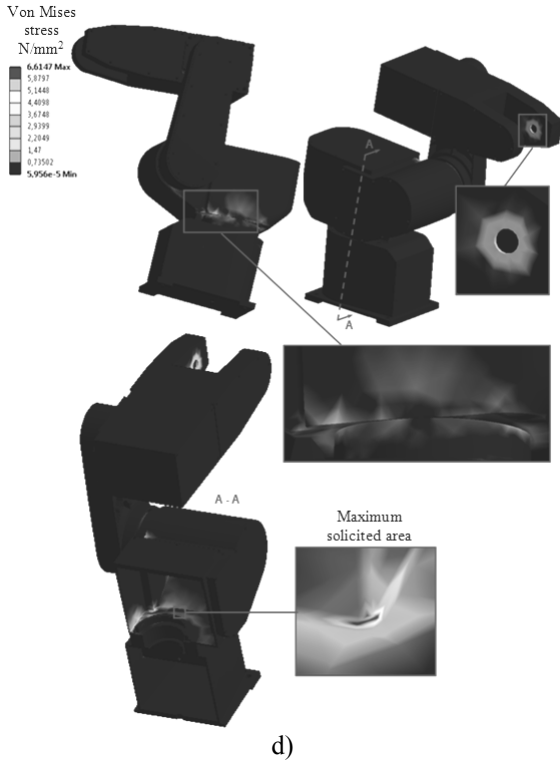

Fig. 5. Variation of total displacements (a) according to application nodes of efforts [4]

Table 1

The maximum numerical values of total displacements and von Mises stresses

	Working position of the robot Fanuc RL Mate 100iB				
	Application node of the efforts				
	2	3	6	7	8
Maximum total displacements [mm]	0,0077714	0,033958	0,011807	0,030377	0,020436
Maximum von Mises stresses N/mm ²	28,3	16,087	2,6618	6,6147	6,8759

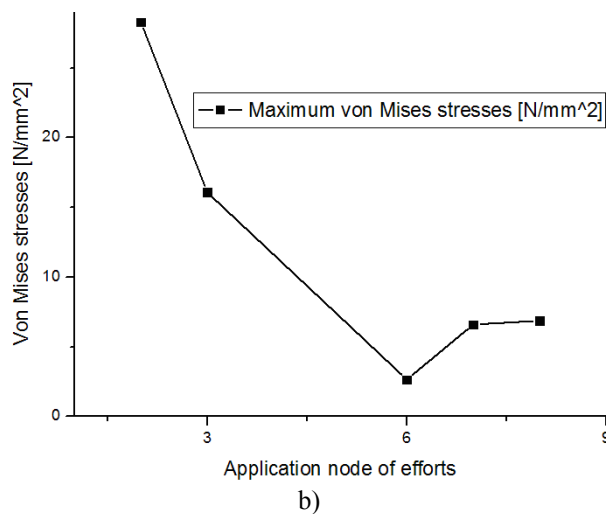

Fig. 5. Variation of von Mises stresses (b) according to application nodes of efforts [4] (continuation)

3. CONCLUSION AND OBSERVATIONS

In this paper has presented:

- a numerical study in static mode to determine the displacements and equivalent stresses in the case of strength structure of the industrial serial robot Fanuc LR Mate 100iB, for a particular chosen working position;
- the maximum value of displacement has obtained for the rotation module (figure 3 b));
- the interested value of displacements is the one obtained over the entire strength structure (figure 3 e)), which is quite low so that will not influence the accuracy of the robot;
- the maximum values of stresses has obtained to the base module, but the von Mises equivalent stress corresponding to the entire structure is quite low, so it will

not have a great influence on the structure of resistance of the robot;

- equivalent von Mises stress values are influenced by the CAD model of the structure and construction of various elements such as beams connection etc.
- the obtained reduced numerical values distinguish that the studied particular working position not raise problems from strength structure and accuracy point of view, even when the robot is loaded with maximum load handling.

Future numerical studies will be made deeper (static and dynamic) and experiments to obtain information as true on the state of stresses and deformations for the Fanuc LR Mate 100iB robot.

ACKNOWLEDGMENT: This paper was supported by the project "Doctoral studies in engineering sciences for developing the knowledge based society - SIDOC" contract no. POSDRU/88/1.5/S/60078, project co-funded from European Social Fund through Sectorial Operational Program Human Resources 2007-2013.

4. REFERENCES

- [1] Bejan, M., *Rezistența materialelor*, vol. 1 (ediția a V-a) și vol. 2 (ediția a IV-a), Editura AGIR, București și Editura MEGA, 2009, Cluj-Napoca, România
- [2] Crețu, A., *Rezistența materialelor*, vol. 1, Editura MEDIAMIRA, 2005, Cluj-Napoca, România
- [3] Simion, Mihaela, *Tensiuni și deformații în structura de rezistență a unui robot industrial serial*, Raport de Cercetare nr. 2 în

- cadrul doctoratului, iunie 2011, Cluj-Napoca, România
- [4] Simion, Mihaela, Botean, A.I., Bejan, M., *Analytic study of efforts from the structure of a industrial serial robot 5R*, Acta Tehnica Napocensis, Series: Applied Mathematics and Mechanics, vol. 54, Issue 1, ISSN 1221-5872, pag. 225-228, 2011, Cluj-Napoca, România
- [5] Simion, Mihaela, Botean, A.I., Bejan, M., *Studiul analitic și numeric al deplasărilor pentru o grindă articulată*, Știință și Inginerie, vol. 19, Editura AGIR, București, 2011, ISSN 2067 – 7138, pag. 657-666, 2011, Cluj-Napoca, România
- [6] tutoriale ANSYS 12.1
- [7] *** www.fanucrobotics.com

Analiza numerică a stării de tensiuni și deformații ale unui robot industrial serial 5R

Rezumat. Lucrarea de față prezintă o analiză numerică pentru determinarea deplasărilor și tensiunilor în cazul structurii de rezistență a unui robot industrial serial 5R. Această analiză numerică cu metoda elementului finit cuprinde studiul robotului atunci când acesta este încărcat cu forța maximă de manipulare, pentru a realiza o mișcare simplă de pick&place.

Mihaela Simion Eng., PhD. Student, Technical University of Cluj-Napoca, Department of Strength Materials, email: mihap_elly@yahoo.com.

Ioan-Adrian Botean PhD.Eng., Professor Assistant, Technical University of Cluj-Napoca, Department of Strength Materials, email: Adrian.Ioan.Botean@rezi.utcluj.ro

Mircea Bejan PhD.Eng., Proffesor, Technical University of Cluj-Napoca, Department of Strength Materials, email: Mircea.Bejan@rezi.utcluj.ro